



Non-Synchronous Energy Electronics, LLC



Grid Stability Solutions;

A description of the solutions offered for grid stability, including an

**Energy Storage Driven Synchronous Condenser System
(ESDSYC)**

vs

A Free-Wheeling Sync Condenser w/BESS

**Alan McDonnell, President, NSEE
Kyle Rewcastle, P.Eng. Sabre**

Oct. 2025

NSEE is partnered with Sabre Canada of Calgary and Indrivetec of Zurich to deliver complete ESDSYC (Energy Storage Driven Synchronous Condenser) Projects, and other PCS Projects, in Canada & the USA



- Sabre Canada, based in Calgary, is the commercial lead on the projects
- Sabre packages the Power Converter Systems, transformers and switchgear at their facility in Calgary



- Indrivetec provides the power converters from their factory in Bulgaria, and engineering and technical support from their head office in Zurich



SWISS engineering



Presentation Description

The need for Grid Stability and Power Quality solutions;

This presentation describes the variety of solutions that NSEE/Sabre can supply for Grid Stability and Reliability due to increased IBR Penetration and Data Centers with fast changing loads.

We concur that it should be the burden of a data center developer to include power conditioning systems that will smooth out the load drawn from the grid, such that it appears stable, and can even help support instabilities in the grid caused by others or events.

This presentation also shows how our Novel ESDSYC can offer big improvements in stability and oscillation damping over free-wheeling synchronous condensers.

P5 of the presentation shows test results from NREL of using a free-wheeling sync condenser with flywheel in parallel with a grid forming BESS under a frequency dip, and the time and amount of rating from the BESS to stabilize the oscillations, compared to our P11 results for damping after a phase angle jump.

An example of an SC/BESS in parallel as a solution that is being used to add inertia and fault current contribution to the BESS.

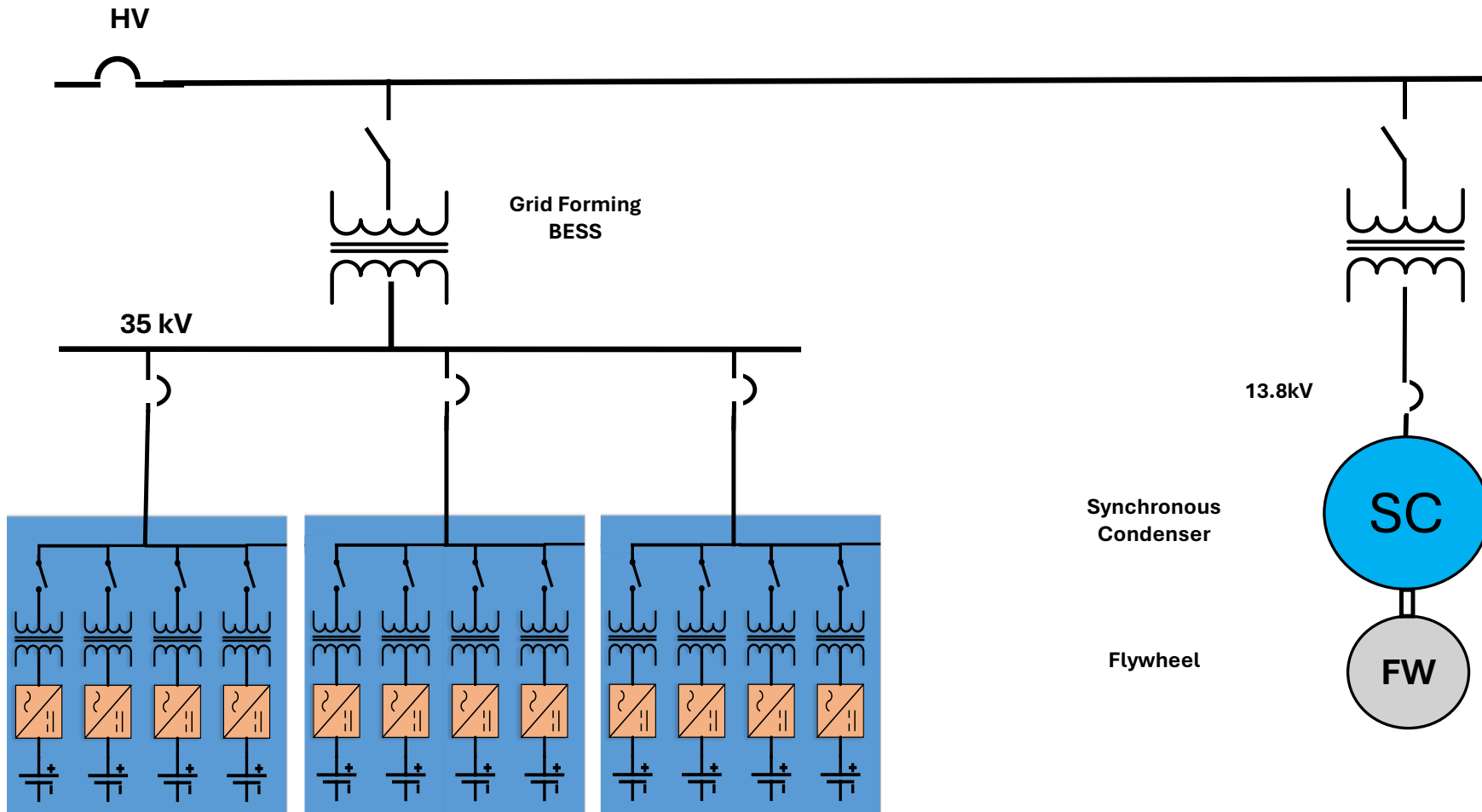

A performance example (NREL) of a parallel connected Sync Condenser and BESS with grid forming inverter

In order to produce a steady state FFR output, the BESS needs to be sized at 275% of the Continuous output in order to stabilize the sync condenser

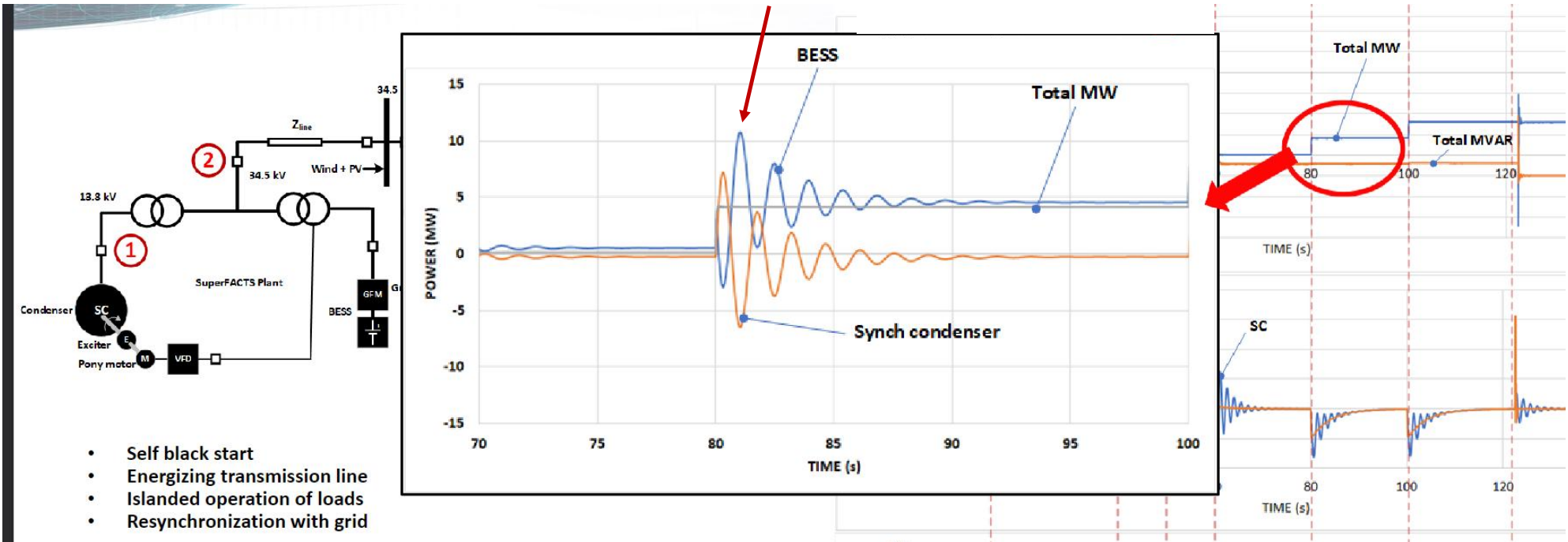

- Self black start
- Energizing transmission line
- Islanded operation of loads
- Resynchronization with grid

The time to settle the oscillations for a step change in load is about 8 sec.

An example of an ESDSYC/BESS

**Note that the whole system is considered grid forming at the POI*

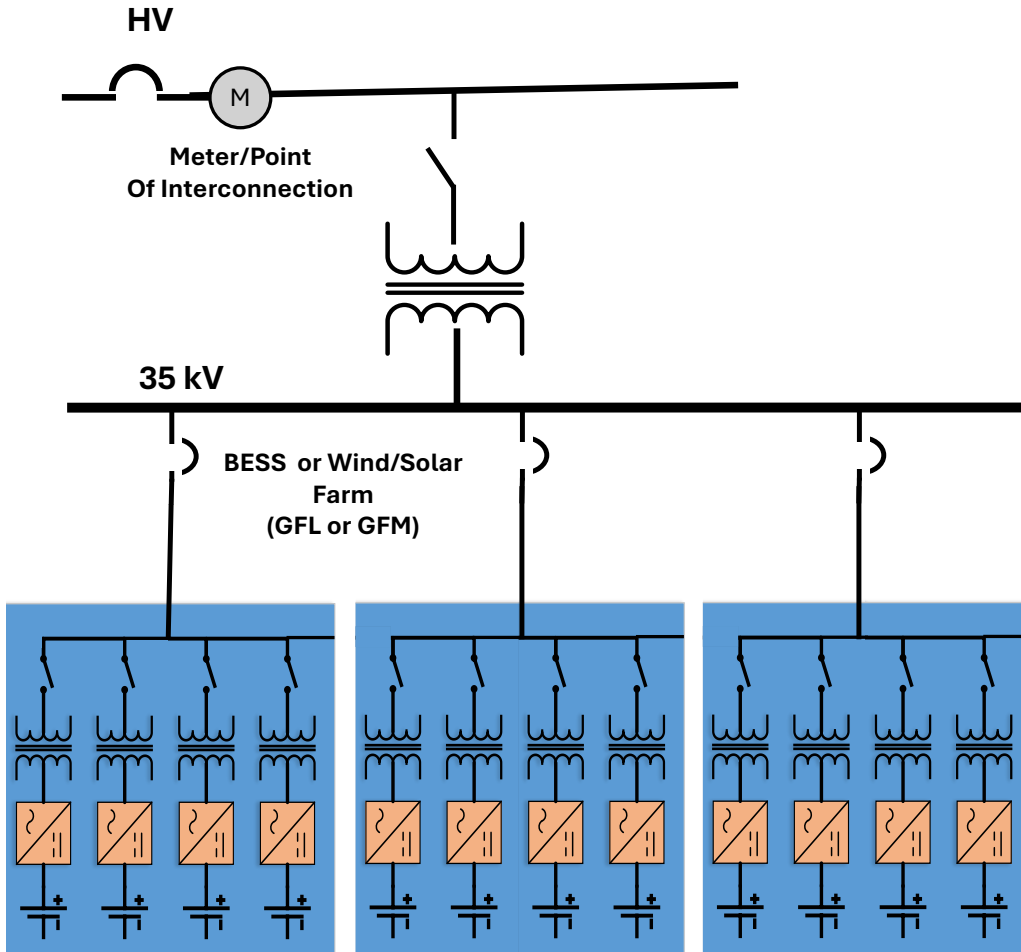

**By driving the sync generator with an induction motor, like a gas turbine, the whole system acts like a gas turbine to the grid, but with the ability for bi-directional power flow and much faster dynamic performance*

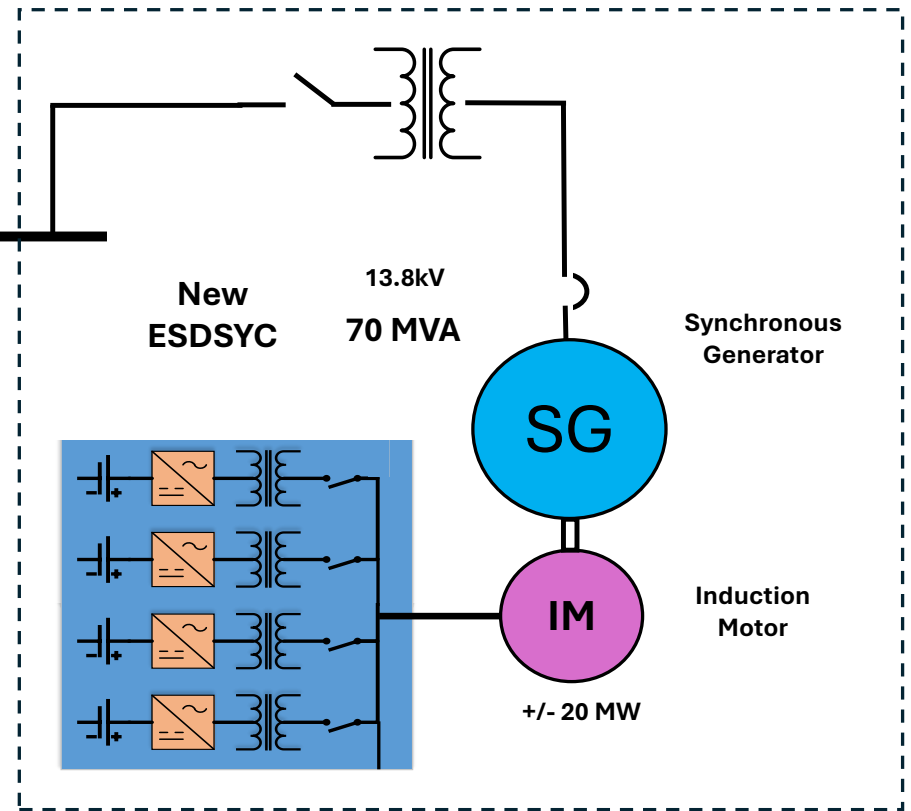

Pilot Project Risk Mitigation Plan



In the event that there are problems with control or coupling of the induction motor, the system could be re-configured to run as a standard BESS with a Sync Condenser.

The new BESS could also be used as a static freq. converter to start the SC

The ESDSYC is agnostic to the battery vendor choice.

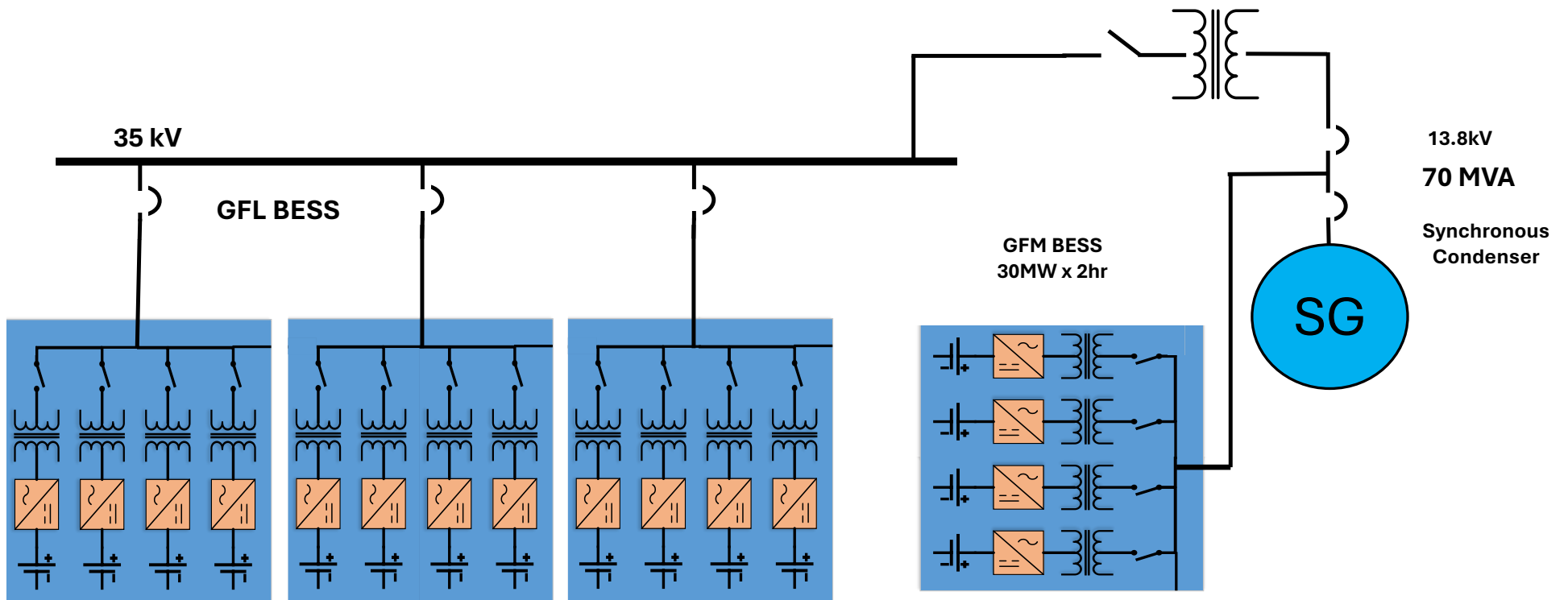



This system simply replaces the turbine that usually drives a standard synchronous generator with an induction motor.

In this case, the generator can also be used as a synchronous motor to drive energy into the batteries

The energy to drive the generator comes from the batteries, instead of gas or steam through a turbine, through the power converters, like a VFD, which can also absorb power, like in dynamic braking mode.



A more detailed description of an ESDSYC as envisioned, sized similar to an LM6000 gas turbine

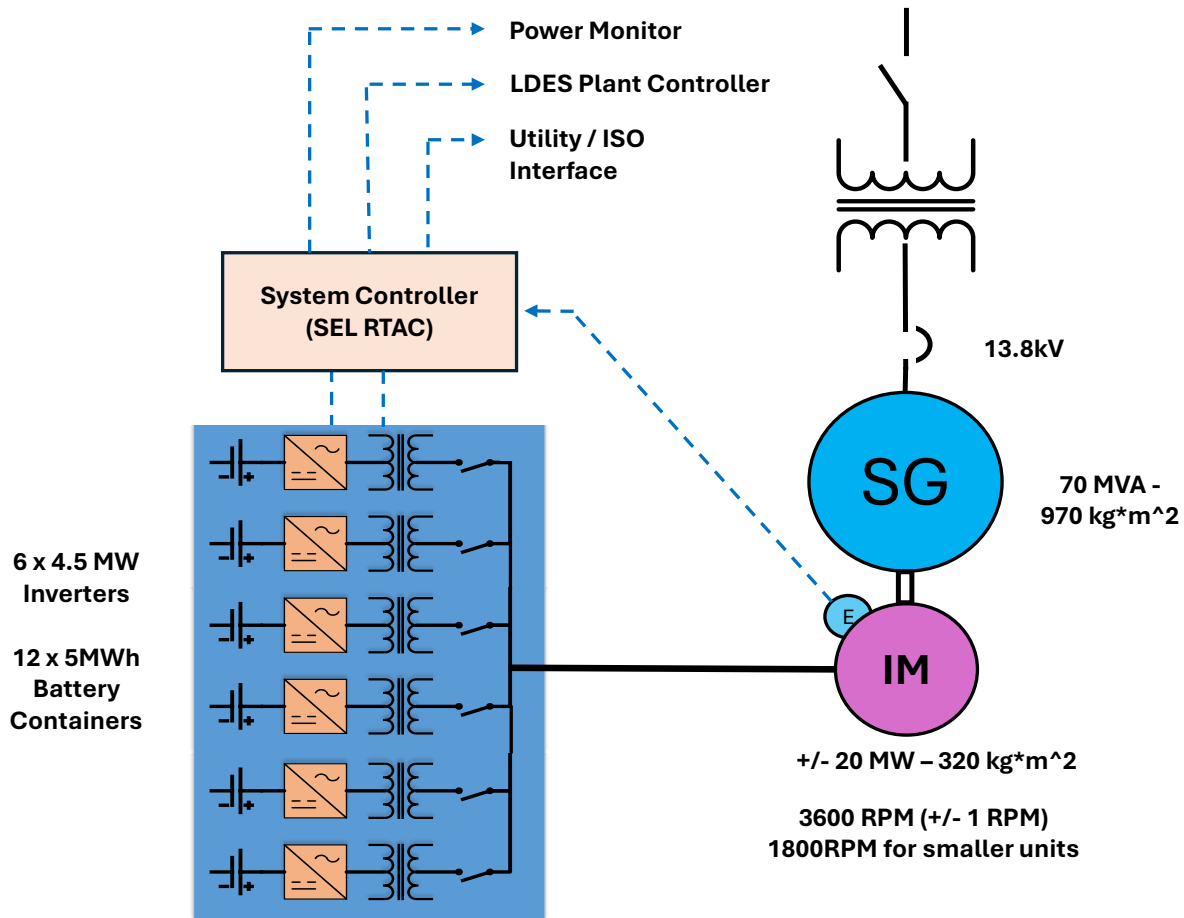

- Basic System Layout of an ESDSYC
- Batteries are used as an energy source to drive the generator with very tight speed and/or torque control modes
- The sync condenser runs connected 24/7, acting as both a motor and a generator
- Shaft speed can be monitored very accurately and torque changes can be made very quickly
- In normal operating mode, speed is monitored and torque is controlled, within battery and inverter limits and outside parameters and grid monitoring available as control signals also
- Under grid fault conditions, the sync machine provides system inertia, fault current and can ride through grid faults and phase angle jumps.

FFR Performance evaluation comparison between ESDSYC and a standard inverter BESS



Comparison between ESDSYC, with 30MW IM Power shown, and a standard 50MW BESS, same -5Hz/Sec. RoCoF

Generally about 150mSec vs 250mSec to full output

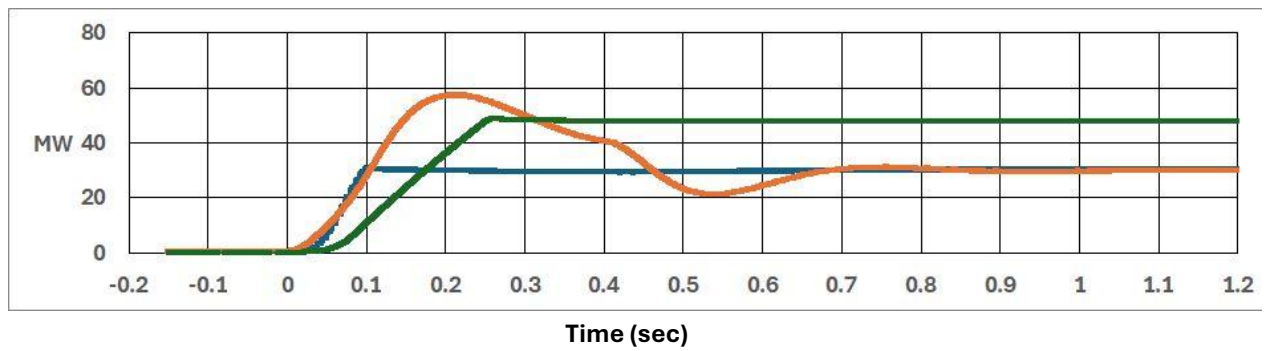

Comparison of a standard 100MW BESS under FFR vs. an 80MW BESS combined with a 20MW Induction Motor ESDSYC

Generally about 80mSec. Faster to full power and an extra 30MW short term inertia boost

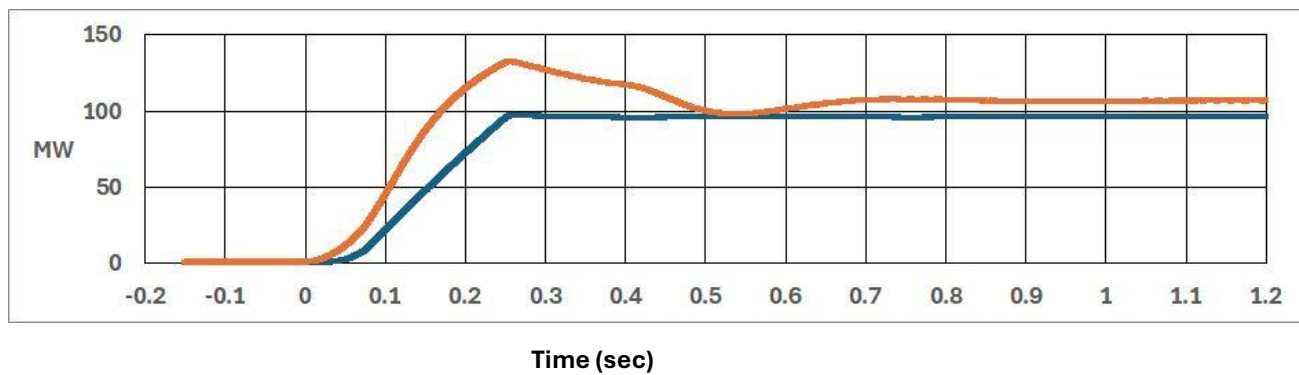

FaFR (Faster Frequency Response)

FFR Performance evaluation comparison between ESDSYC and a free-wheeling Synchronous Condenser



(based on an existing Wind Farm Interconnection studies)

Grid Frequency Drop to 58Hz at a RoCoF of -5Hz/sec

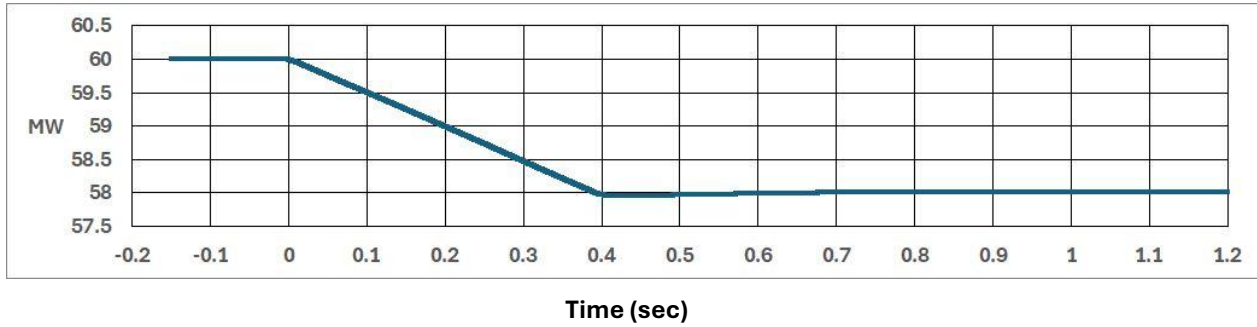

Power output response of the Sync Condenser under driven ESDSYC compared to a free-wheeling SC

*note that the 20MW Induction Motor is driven at 30MW for 30Sec. Before settling at 20MW for continuous duty.

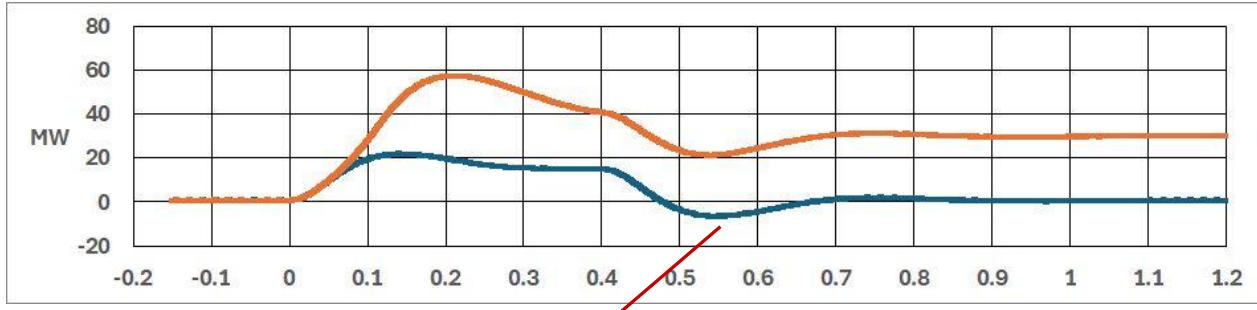

*note that the free-wheeling SC drops into negative power as it corrects back to zero, and undesirable feature during FFR events.

Example ESDSYC Power Output Response



25 deg. Phase Angle Jump; also an example of system oscillation damping

Phase angle jump 25 deg
Case B: (Natural) inertia response
+ P(f) droop through inverter control

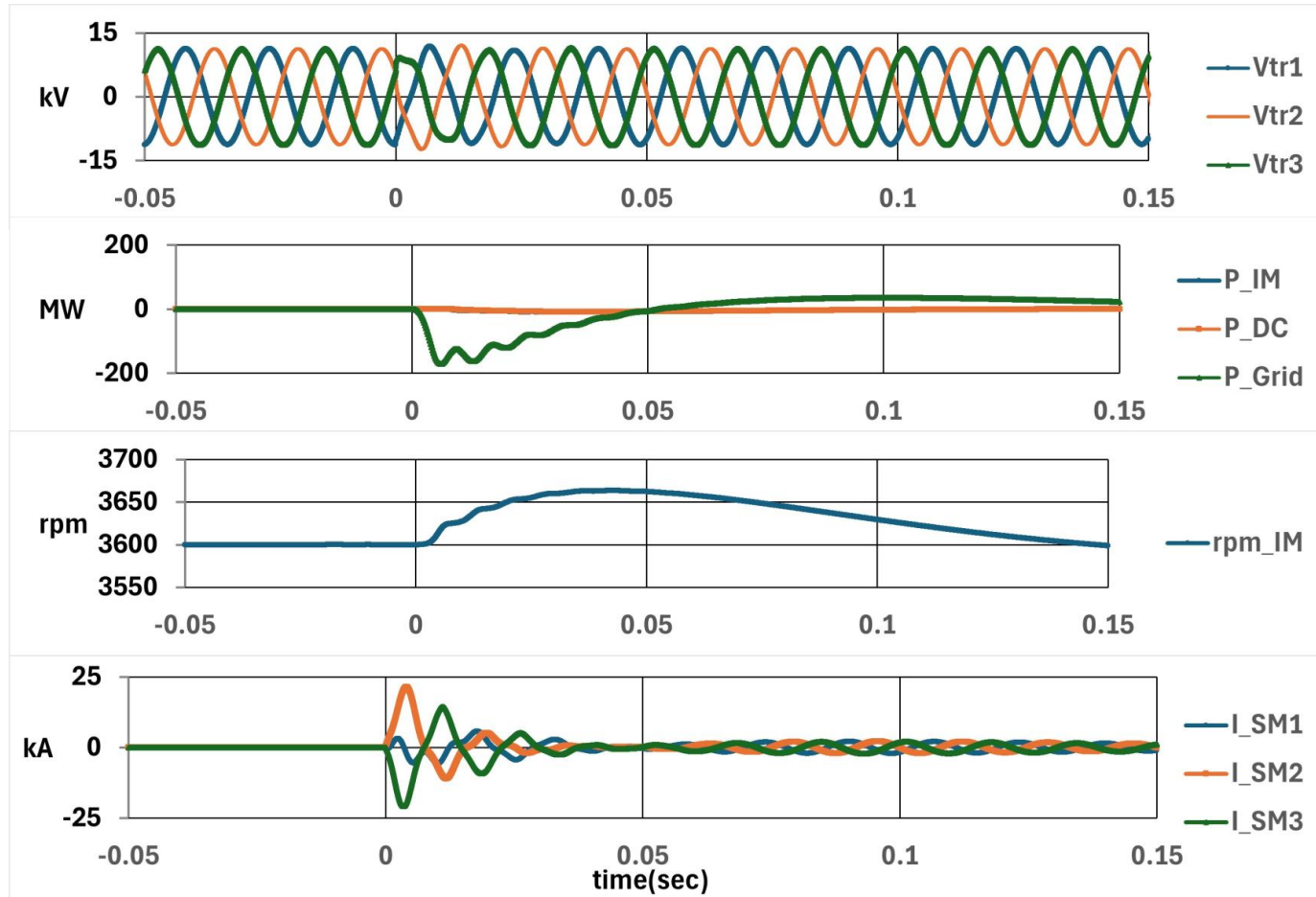

A phase angle jump is simulated by switch-over between two grid supplies with 25 degrees phase displacement. The current and torque transients are largely settled in about 50 msec, without loss of synchronization



Non-Synchronous Energy Electronics, LLC

These, and other customized applications can be configured as needed. We look forward to discussing in further detail. For more information, please contact;

Alan McDonnell, President

Non-Synchronous Energy Electronics, LLC

5115 Excelsior Blvd., #330

St. Louis Park, MN 55416

(603) 546-5785

alan.mcdonnell@nonsynchronous.com

Kyle Rewcastle, P.Eng.

Sabre Canada Inc.

(403) 850-3002

kyle.rewcastle@sabre.ca

www.nonsynchronous.com